



Type A Energy Wheels

**for Modular and T-Series
Climate Changer™ Air Handlers**



Contents

Introduction	3
Features and Benefits	4
Energy Wheel Construction	5
Application Considerations	7
Performance Calculations.....	10
Cleaning Requirements	15
MCC Dimensions and Weights	16
T-Series Dimensions and Weights.....	18



Introduction

This product catalog provides information about the Type A Trane energy wheel, its features and benefits, selection details, and specific guidelines to assure an effective system design for the Modular Climate Changer™ (MCC) and T-Series™ Climate Changer air

handlers. Review this material carefully before beginning the design process.

A general overview of energy wheels is provided in engineering bulletin, CLCH-PRB012-EN, including appli-

cation guidelines for the energy wheel module/section.

Please contact your local Trane sales engineer for additional design support or to answer technical questions that go beyond the scope of this product catalog.



Features and Benefits

The primary feature of the Trane Type A energy wheel is that it is ARI 1060 certified and UL recognized, assuring performance per specifications and enabling quick approvals. ARI Standard 1060 is the standard for rating air-to-air energy recovery ventilation equipment. Other features and benefits include:

- An all-welded, stainless steel wheel assembly that is independent of the heat transfer media, resulting in corrosion resistance and long service life
- Removable energy transfer segments, allowing the wheel media to be cleaned easily, which contributes to long life expectancy and sustained effectiveness
- A laminar flow, self-cleaning matrix that requires little maintenance
- Energy efficient ventilation to reduce operating costs
- The ability to increase ventilation, allowing for improved indoor air quality (IAQ)
- High efficiency, which permits increased outdoor air quantity without increasing the heating or cooling plant.

ARI 1060 Certification

Trane Modular Climate Changer™ (MCC) and T-Series™ Climate Changer air handlers are certified to use an ARI 1060 certified energy wheel. ARI Standard 1060 is a certification program that verifies the performance characteristics of energy wheels, air-to-air plate exchangers, and heat pipes. The performance characteristics certified by ARI Standard 1060 are:

- Total effectiveness
- Latent effectiveness
- Sensible effectiveness
- Exhaust air transfer ratio (EATR) — The percentage of the exhaust air that crosses over into the supply air
- Outside air correction factor (OACF) — The ratio of the entering outside airflow divided by the leaving ventilation (supply) airflow
- Pressure drop — The supply and exhaust airflow pressure drops

In ARI Standard 1060, the sensible, latent, or total effectiveness of an air-to-air heat exchanger for use in energy recovery ventilation equipment is described by the following equation:

$$E = \frac{m_s(x_1 - x_2)}{m_{\min}(x_1 + x_3)}$$

where:

- E = sensible, latent, or total effectiveness
- x = dry bulb temperature (for sensible effectiveness) in °F [°C] or absolute humidity ratio (for latent effectiveness) in grains/lb [grams/kg] or total enthalpy (for total effectiveness) in Btu/lb [J/kg]
- m_s = mass flow rate in units of mass of dry air per unit time lb/hr [kg/hr]

where:

- subscript "s" refers to the supply air
- subscript "min" refers to the minimum of the exhaust and supply values
- subscripts 1, 2, and 3 indicate measurement stations as defined in Section 7.4.2.4 of ASHRAE Standard 84 (1 is the entering supply air, 2 is the leaving supply air, and 3 is the entering exhaust or return air).

Trane uses net effectiveness, the true effectiveness at which the energy recovery device performs without the benefits of the transferred exhaust air, which may affect the leaving air temperature. Because the effects of exhaust air cannot be subtracted during testing, the measured effectiveness and net effectiveness numbers are both reported in the directory. Trane energy wheels have minimal exhaust air transfer, so these two numbers are close to equal.

To obtain a copy of the standard or to view Trane's latest certified data in the official ARI 1060 directory, go to ARI's Web site at www.ari.org.

Energy Wheel Construction

Type A energy wheels incorporate an all-welded stainless steel hub, spoke, and rim assembly, which is independent of the heat transfer matrix. The heat transfer matrix is contained in patented energy transfer segments that can be removed from the wheel without using tools. The Type A energy wheel uses a unique parallel plate geometry and polymer film substrate to provide an optimized heat exchanger design. The polymer film substrate reduces the problem of axial heat flow, allowing for a lighter-weight wheel with a thinner profile.

Permanently lubricated wheel bearings provide an L-10, 400,000-hour life expectancy. A urethane stretch belt perimeter drive system eliminates the need for gear drive motors, chain drives, and idler tension devices. Permanent split capacitor (single-phase) and high efficiency (three-phase) motors are used in combination with the lightweight wheel construction to minimize electrical requirements.

Silica gel desiccant is used for its superior water sorption properties in the relative humidity working range encountered in air conditioning applications. The desiccant is

physically embedded in the surfaces of the polymer film without the use of adhesives, allowing the segments to be washed repeatedly without significant loss of material. Washing the Type A wheel restores latent performance in wheels that have experienced a reduction in latent capacity due to coating with tars or oil-based aerosols.

Silica gel is a dry desiccant with an affinity for water molecules and a high working capacity at relative humidities above 30 percent relative humidity. As shown in Figure 1, silica gel has a greater capacity for adsorption and desorption of

Figure 1. Desiccant comparison (after W.R. Grace, Davison Chemical Division, "Silica Gels")

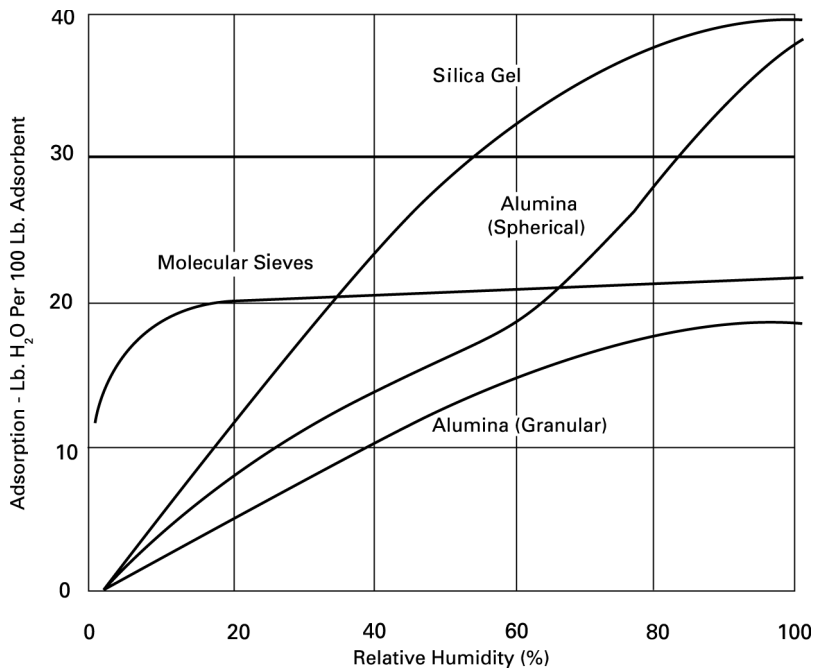



water than the same amount of other desiccants at relative humidities in excess of 30 percent. This capacity is important because the energy recovery ventilation application treats outdoor air with relative humidity typically in the 40 to 80 percent range. Indoor

relative humidity is 50 percent for cooling design and may range from 30 to 50 percent for humidified buildings in the winter heating application. At these conditions, molecular sieve-based wheels would require larger amounts of desiccant to achieve compa-

table performance to the silica gel-based wheel. In addition, the unique interactions of silica gel with the water molecule dipole gives silica gel a strong preference for sorption of water as opposed to other airborne molecules.

Application Considerations

Electrical Power

Separate single or three-phase power must be run to the energy wheel module (see Table 1). The energy wheel motor is provided with thermal protection.

The MCC energy wheel module is provided with an external 4" x 4" junction box for field power connection. A starting contactor must be supplied and installed.

Power is connected to the T-Series energy wheel section through the high voltage electrical penetration in the exhaust fan section.

Temperature Limits

- 150°F (66°C) maximum
- -20°F (-29°C) minimum

Colder ambient temperatures can be tolerated, provided the module/section is oriented so the drive motor is in a warmer air stream.

Cross Leakage and Purge

All energy wheels have some cross leakage and purge, so do not use energy wheels in application involving toxic or hazardous air streams. The percentage of cross leakage

depends on the pressure differentials across the wheel section. With Trane energy wheels the exhaust air transfer ratios are typically low (<3%).

Fan placement can affect the pressurization of the two air streams, which controls the direction that the seal-related leakage moves. Therefore, fan placement can be used to direct that leakage. Table 2 describes the ways in which fans can be arranged to direct the cross leakage. *Remember that exhaust and supply air fans must be arranged to provide counterflow airflow through the energy wheel.*

Table 1. Type A energy wheel electrical requirements, standard motor data¹

Wheel Size (nominal cfm)	Motor hp	Motor voltage/phase	Motor Hz	Motor Amperage
1,500	1/6 hp	200-208/240 volt, single-phase	50/60	1.1
3,000	1/2 hp	200-208/240 volt, single-phase	50/60	2.7
	1/6 hp	200-230/460 volt, three-phase	50/60	1.04/0.52
4,000, 5,000	1/2 hp	200-208/240 volt, single-phase	50/60	2.7
	1/6 hp	200-230/460 volt, three-phase	50/60	0.84/0.38
6,000–25,000	1/4 hp	200-230/460 volt, three-phase	60	1.6/0.8

1. Optional voltages, which differ from the above, are available for the 3-5K wheel.

Table 2. Fan arrangement comparison

Arrangement	Cross Leakage Path	Comments
Draw-thru supply and exhaust and blow-thru supply and exhaust	Either direction depending on the static pressures in the supply and exhaust chambers	Provides lower leakage as designed. There is little control over seal-related leakage over the life of the equipment as filters clog and air streams go out of balance.

Table 2. Fan arrangement comparison (continued)

Arrangement	Cross Leakage Path	Comments
Blow-thru supply/ draw-thru exhaust	Supply to exhaust	Any seal-related leakage goes into the exhaust air stream. This arrangement is recommended when minimum cross leakage from exhaust to supply is desired.
Draw-thru supply/ blow-thru exhaust	Exhaust to supply	This arrangement is <i>not</i> recommended

Figure 2. Exhaust air transfer ratio (EATR) for equal airflows

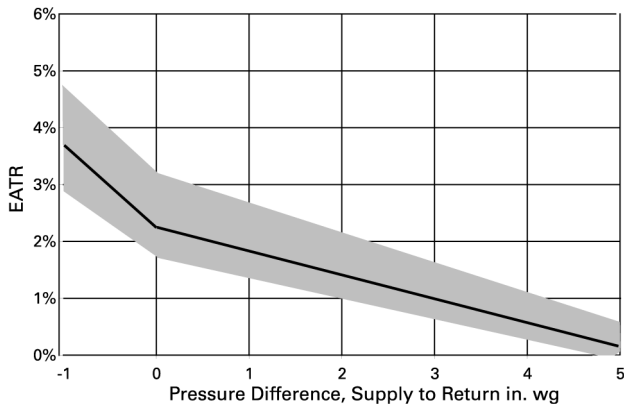
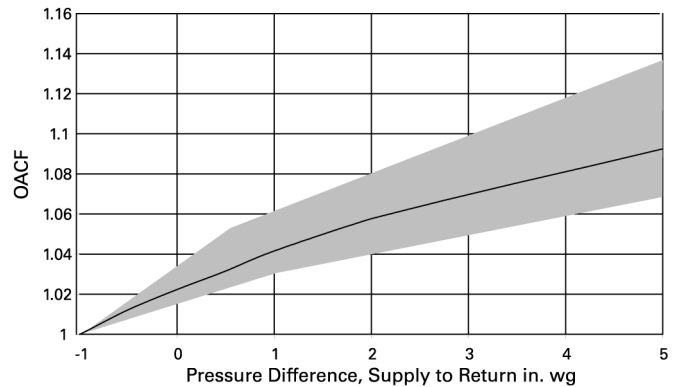

Figure 3. Outside air correction factor (OACF) for equal airflows



EATR and OACF values are needed to size the fans properly. These values vary depending on the wheel size and airflow. Figure 2 and Figure 3 represent the average EATR and OACF values for the Trane energy wheel. For exact values, use the Trane Energy Recovery software program.

The placement of the fans affects how much airflow the fans receive. The following formulas can help determine the airflow through the fan.

- Draw-thru supply fan CFM = (Outside air ventilation requirement CFM) x (1+EATR)

- Draw-thru exhaust fan CFM = (Required Exhaust CFM) x (1+OATR)
- Blow-thru supply fan CFM = (Outside air ventilation requirement) x (1+OATR)
- Draw-thru exhaust fan CFM = (Required exhaust CFM) x (1+OATR)
- Blow-thru supply fan CFM = (Outside air ventilation requirement) x (1+OATR)
- Blow-thru exhaust fan CFM = (Required exhaust CFM) x (1+EATR)

Where:

- OATR = (1+EATR) x (OACF) - 1
- Measured outside air CFM = (Outside air ventilation requirement) x (1+OATR)
- Actual unit supply CFM =

$$\text{(Desired outside air)} \times (1+\text{EATR})$$

Because the MCC air handler is flexible, any one of the three fan arrangements may prove to be the best one. When determining an energy recovery unit layout, consider each configuration. In some cases, all three may be acceptable for the job, but in most cases, a blow-thru supply/draw-thru exhaust orientation produces the lowest EATR — with a high fan penalty. To minimize the fan penalty, arrange the fans in the configuration that results in the lowest pressure differential between the wheel supply, C,

and the wheel return, D (see Figure 4).

Figure 4. MCC energy wheel orientation

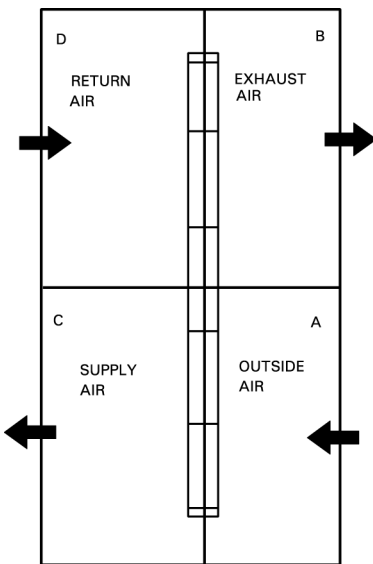

Example Energy Wheel Orientation

In this example, the energy wheel will be used in a 10,000 cfm, 100 percent outside air unit with:

- 0.85 in. wg coil pressure drop
- 1.50 in. wg return external static pressure
- 0.50 in. wg exhaust external static pressure
- 2.00 in. wg supply external static pressure
- 0.20 in. wg outside air static pressure
- 0.25 in. wg outside air filter and damper pressure loss

- 1.07 in. wg wheel pressure drop

Blow-Thru Supply, Draw-Thru Exhaust

In a blow-thru supply, draw-thru exhaust configuration, the purge volume can become significant if items such as a final filter are added to the system. To minimize this fan penalty, a blow-thru supply and exhaust configuration can be used.

Pressure@C = +0.5" + 2" = +2.5"
 Pressure@D = -1.50
 $\Delta P, C \text{ to } D = +2.50 - (-1.5) = 4 \text{ in. wg}$
 OACF = 1.08; EATR = 0.6%; OATR = 0.066
 Supply Fan CFM = 10,000 x (1 + 0.066) = 10,660 cfm
 Exhaust Fan CFM = 10,000 x 1.066 = 10,660 cfm
 Inlet Outside Air CFM = 10,000 x 1.066 = 10,660 cfm
 Unit Supply CFM = 10,000 x 0.006 = 10,060 cfm

Blow-Thru Supply, Blow-Thru Exhaust

Pressure@C = +0.5" + 2" = +2.50"
 Pressure@D = +1.07" + 0.50" = +1.57"
 $\Delta P, C \text{ to } D = 2.5" - (+1.57") = 0.93"$
 OACF = 1.04; EATR = 1.9%; OATR = 1.06
 Supply Fan CFM = 10,000 x 1.06 = 10,600 cfm
 Exhaust Fan CFM = 10,000 x 1.019 = 10,190 cfm
 Inlet Outside Air CFM = 10,000 x 1.06 = 10,600 cfm
 Unit Supply CFM = 10,190 cfm

Draw-Thru Supply, Draw-Thru Exhaust

Pressure@C = -1.07" - 0.25" - 0.2" = -1.52"

Pressure@D = -1.50"
 $\Delta P, C \text{ to } D = -1.52" - (-1.50") = -0.02 \text{ in. wg}$
 OACF = 1.02; EATR = 2.2%; OATR = 1.042
 Supply Fan CFM = 10,000 x (1 + 0.022) = 10,220 cfm
 Exhaust Fan CFM = 10,000 x (1 + 0.042) = 10,420 cfm
 Inlet Outside Air CFM = 10,000 x 1.042 = 10,420 cfm
 Unit Supply CFM = 10,220 cfm

In this example, the draw-thru supply and exhaust configuration has the lowest fan penalty and produces a small EATR. It is the preferred arrangement for this example application. The blow-thru supply/draw-thru exhaust arrangement provides the lowest EATR but uses significantly more fan energy than the other arrangements because of the amount of outside air being purged. Because typical applications of energy wheel systems include schools, offices, dormitories, and casinos, wheel purge offers no value to most customers. If conditions exist in which a purge needs to be induced, a purge sector can be ordered from the factory.

A T-Series air handler is always in a draw-thru supply and exhaust configuration when using an energy wheel. The same procedure can be followed to approximate the cross leakage. Use the Trane Energy Recovery software to obtain exact values.



Performance Calculations

Choose the Unit Size

Other unit components of the air handler, such as the cooling coil and the amount of return air for mixed airflow units, may require a minimum unit size. Figure 5 and Figure 6 show the

availability of Trane energy wheels per unit size. Typically, per unit size, there is one 100 percent outside air wheel option and several partial wheel options sized for 25–65 percent outside air. Use the 100

percent outside air wheel option for units that have over 70 percent outside airflow. Also, make sure the wheel size is available with the unit size.

Figure 5. MCC wheel options

Wheel Option (cfm)	MCC Unit Sizes												
	3	6	8	10	12	14	17	21	25	30	35	40	50
1500	■	■	■	■	■	■	■	■	■	■	■	■	■
3000	■	■	■	■	■	■	■	■	■	■	■	■	■
4000	■	■	■	■	■	■	■	■	■	■	■	■	■
5000	■	■	■	■	■	■	■	■	■	■	■	■	■
6000	■	■	■	■	■	■	■	■	■	■	■	■	■
7000	■	■	■	■	■	■	■	■	■	■	■	■	■
8500	■	■	■	■	■	■	■	■	■	■	■	■	■
10500	■	■	■	■	■	■	■	■	■	■	■	■	■
12500	■	■	■	■	■	■	■	■	■	■	■	■	■
15000	■	■	■	■	■	■	■	■	■	■	■	■	■
17500	■	■	■	■	■	■	■	■	■	■	■	■	■
20000	■	■	■	■	■	■	■	■	■	■	■	■	■
25000	■	■	■	■	■	■	■	■	■	■	■	■	■

■ Partial Flow Wheel Option (mixed air units)
 ■ 100 Percent Outside Air Wheel Option

Figure 6. TSC wheel options

Wheel Option (cfm)	T-Series Unit Sizes													
	8	10	12	14	17	21	25	30	35	40	50	66	80	100
1500	■	■	■	■	■	■	■	■	■	■	■	■	■	■
3000	■	■	■	■	■	■	■	■	■	■	■	■	■	■
4000	■	■	■	■	■	■	■	■	■	■	■	■	■	■
5000	■	■	■	■	■	■	■	■	■	■	■	■	■	■
6000	■	■	■	■	■	■	■	■	■	■	■	■	■	■
7000	■	■	■	■	■	■	■	■	■	■	■	■	■	■
8500	■	■	■	■	■	■	■	■	■	■	■	■	■	■
10500	■	■	■	■	■	■	■	■	■	■	■	■	■	■
12500	■	■	■	■	■	■	■	■	■	■	■	■	■	■
15000	■	■	■	■	■	■	■	■	■	■	■	■	■	■
17500	■	■	■	■	■	■	■	■	■	■	■	■	■	■
20000	■	■	■	■	■	■	■	■	■	■	■	■	■	■
25000	■	■	■	■	■	■	■	■	■	■	■	■	■	■

■ Partial Flow Wheel Option (mixed air units)
 ■ 100 Percent Outside Air Wheel Option



Choose the Wheel Size

The required ventilation CFM determines the size of the energy wheel. Refer to Table 3

and Table 4 for CFM ranges in choosing the correct wheel size. Base your selection on the larger of the supply or return

CFM when using unequal airflows.

Table 3. Trane Type A energy wheel, pressure loss, ΔP (in. wg) and total effectiveness (wheel sizes 1,500–8,500)

Wheel Size	1,500		3,000		4,000		5,000		6,000		7,000		8,500	
Actual														
Airflow (cfm)	ΔP	% Eff	ΔP	% Eff	ΔP	% Eff	ΔP	% Eff	ΔP	% Eff	ΔP	% Eff	ΔP	% Eff
600	0.39	82												
800	0.51	82												
900	0.57	81												
1000	0.63	80												
1200	0.78	75												
1400	0.87	76	0.54	82										
1600	1.00	74	0.61	81										
1800	1.12	72	0.68	79										
2000			0.75	78										
2200			0.83	77										
2400			0.90	76										
2500			0.93	75										
2600			0.97	75	0.78	78								
2800			1.04	73	0.84	77								
3000			1.12	72	0.89	76								
3500					1.04	73	0.74	78						
3900					1.16	71	0.82	77						
4000					1.19	71	0.84	77						
4500							0.94	75						
5000							1.05	75	0.87	76				
5500							1.15	71	0.96	75				
6000							1.25	70	1.04	73	0.89	76		
6500									1.13	72	0.96	75		
7000									1.21	70	1.03	74	0.89	76
7500											1.10	70	0.95	75
8000											1.17	71	1.01	74
9000													1.13	73
10000													1.26	69



Table 4. Trane Type A energy wheel, pressure loss, ΔP (in. wg) and total effectiveness (wheel sizes 10,500–25,000)

Wheel Size	10,500		12,500		15,000		17,500		20,000		25,000	
Actual Airflow (cfm)	ΔP	% Eff	ΔP	% Eff	ΔP	% Eff	ΔP	% Eff	ΔP	% Eff	ΔP	% Eff
8000	0.86	76	0.70	79								
9000	0.96	75	0.79	77								
10000	1.07	73	0.87	76	0.77	78						
11000	1.17	71	0.95	75	0.84	77	0.76	78				
12000			1.04	73	0.92	75	0.83	73				
13000			1.13	72	0.99	74	0.90	76				
14000			1.21	70	1.07	73	0.97	74				
15000					1.14	71	1.03	73	0.80	77		
16000					1.22	70	1.10	72	0.86	76		
17000							1.17	71	0.91	76		
18000							1.24	70	0.96	75	0.93	75
19000									1.01	74	0.89	76
20000									1.07	73	0.93	75
21000									1.12	72	0.98	74
22000									1.17	71	1.02	74
23000									1.22	70	1.07	73
24000											1.11	72
25000											1.16	71
26000											1.20	70

Determine Wheel Effectiveness

To calculate the supply and exhaust air conditions leaving the wheel, you must know the wheel effectiveness. Refer to Table 3 for total effectiveness measurements. Note that the effectiveness numbers shown assume equal supply and exhaust airflows. If the airflows are unbalanced, the effectiveness changes. Use the Trane Energy Recovery software to determine effectiveness values for these conditions.

Calculate Wheel Performance

Use the following equations to calculate supply air conditions. Use the Trane Energy Recovery Performance software to calculate exhaust air conditions and to obtain actual dry bulb temperature and enthalpy values for coil and equipment sizing.

Dry Bulb Temperature:

Cooling: $T_{sa} = T_{oa} - (E \times (T_{oa} - T_{ra}))$

Heating: $T_{sa} = T_{oa} + (E \times (T_{ra} - T_{oa}))$

where:

T_{sa} = Dry bulb temperature of supply air (°F)

T_{oa} = Dry bulb temperature of outside air (°F)

T_{ra} = Dry bulb temperature of return air (°F)

E = Sensible Effectiveness

Enthalpy:

Cooling: $H_{sa} = H_{oa} - (E \times (H_{oa} - H_{ra}))$

Heating: $H_{sa} = H_{oa} + (E \times (H_{ra} - H_{oa}))$

where:

H_{sa} = Enthalpy of supply air (btu/ lb)

H_{oa} = Enthalpy of outside air (btu/ lb)

H_{ra} = Enthalpy of return air (btu/lb)

E = Total Effectiveness

After calculating these two points, use a psychrometric chart to obtain the supply air wet bulb temperature and/or grains moisture.

Example Energy Wheel Application

In this example, a wheel sized for nominal 10,500 cfm will be used for the initial evaluation. Table 5 provides the design data for cooling and heating. The air pressure drop is 1.07 in. wg and the total effectiveness is 73 percent (see Table 3). The total and latent effectiveness values are close to equal for Trane energy wheels. For this example, total effectiveness is assumed to be 73 percent in cooling mode and 75 percent in heating mode. The Trane Energy Recovery software could be used to obtain the exact values.

Supply air conditions, cooling mode:

$T_{sa} = T_{oa} - (E \times (T_{oa} - T_{ra}))$
 $= 95 \text{ °F} - (.73 \times (95 \text{ °F} - 75 \text{ °F}))$
 $= 81 \text{ °F}$

$H_{sa} = H_{oa} - (E \times (H_{oa} - H_{ra}))$
 $= 38.4 \text{ Btu/lb} - (.73 \times (38.4 \text{ Btu/lb} - 26.0 \text{ Btu/lb}))$
 $= 29.3 \text{ Btu/lb}$

According to a psychrometric chart, the supply air wet bulb temperature is 64.4°F, 64 grains/lbm.

Supply air conditions, heating mode:

$T_{sa} = T_{oa} + (E \times (T_{ra} - T_{oa}))$
 $= 10 \text{ °F} + (.75 \times (70 \text{ °F} - 10 \text{ °F}))$
 $= 55 \text{ °F}$

$H_{sa} = H_{oa} + (E \times (H_{ra} - H_{oa}))$
 $= 3.2 \text{ Btu/lb} + (.75 \times (22.7 \text{ Btu/lb} - 3.2 \text{ Btu/lb}))$
 $= 17.8 \text{ Btu/lb}$

According to a psychrometric chart, the supply air wet bulb temperature is 45.5°F, 30 grains/lbm.

When designing the remainder of the air-handling system, be sure to account for the air pressure drop imposed by the energy wheel.

Chiller and Boiler Capacity Reduction

Carefully evaluate the reduction in required chiller and/or boiler capacity when making your final unit selections. Consider factors such as weather data, hours of operation, multiple modules on the project, and the need for redundant capacity. Even a modest cut in the mechanical plant can significantly offset the cost of the energy wheel module, though the actual reduction made in the mechanical plant capacity changes from project to project.

It is imperative that you downsize the heating and cooling equipment when using an energy wheel. Downsizing should be done not only to gain the lower equipment first cost



benefit but also to avoid other system and building problems, including short-cycling of equipment — with subsequent loss of control of building humidity (summertime operation) — and occupant discomfort and complaints due to swings in supply air temperature. This principle is particularly true with direct expansion (DX) systems. Loss of building humidity control could cause microbial growth to flourish in the building, leading to occupant discomfort and

potential building deterioration. For more information, refer to Trane application manual, “Managing Building Moisture” (SYS-AM-15).

The following calculations use the information from the previous example. Use these equations to calculate your own applications’ chiller and boiler capacity reduction.

Chiller capacity reduction, cooling mode:
 $Btu/lb = 4.5 \times SCFM \times (H_{oa} - H_{sa})$

$$Btu/lb = 4.5 \times 10,000 \times (38.4 - 29.3)$$

$$Btu/lb = 409,500 \text{ Btu/lb}$$

$$Tons = \frac{(Btu)/(lb)}{(12,000 \text{ Btu})/(ton)}$$

$$Tons = 409,500/12,000$$

$$Tons = 34.1 \text{ tons}$$

Boiler capacity reduction, heating mode:

$$Btu/lb = 1.085 \times SCFM \times (T_{oa} - T_{sa})$$

$$Btu/lb = 1.085 \times 9000 \times (55 - 10)$$

$$Btu/lb = 439,500 \text{ Btu/lb}$$

$$Boiler \text{ HP} = \frac{(Btu)/(lb)}{(33,446 \text{ Btu})/(HP)}$$

$$Boiler \text{ HP} = 439,500/33,446$$

$$Boiler \text{ HP} = 13.1 \text{ hp}$$

Table 5. Design data for example application

Design Data	Cooling	Heating
Supply airflow (SCFM)	10,000	9,000
Return airflow (SCFM)	10,000	9,000
Outdoor Air Conditions		
Dry bulb/wet bulb	95°F/75°F	10°F/8°F
Enthalpy	38.4 Btu/lb	3.2 Btu/lb
Return Air Conditions		
Dry bulb/relative humidity	75°F/40%	70°F/35%
Enthalpy	26.0 Btu/lb	22.7 Btu/lb

Cleaning Requirements

The need for periodic cleaning is a function of operating schedule, climate, and contaminants in the air streams.

Trane energy wheels are self-cleaning with respect to dry particles. Smaller particles pass through the wheel. Larger particles land on the surface and are blown clear as the wheel turns into the opposite airflow path. For this reason, the primary cleaning need for Trane energy wheels is to remove oil-based aerosol films that have collected on the desiccant surfaces. Such films can close off micron-sized pores at the surface of the desiccant material, reducing its ability to adsorb and desorb moisture. Periodically recording the air temperatures entering and leaving the energy wheel to detect changes in performance is recommended.

In a reasonably clean indoor environment, such as a school or office building, experience shows that reductions of airflow or loss of sensible effectiveness may not occur for ten or more years. Where there is moderate tobacco smoke, or within cooking facilities, reduction in effectiveness can occur much faster. In applications experiencing high levels of tobacco smoke, such as smoking lounges, nightclubs, bars, and restaurants, the energy transfer surfaces may require cleaning as often as every six months. Similar washing cycles may also be appropriate for industrial applications, such as welding or machining operations, involving ventilation of high levels of smoke or oil-based aerosols.

Trane energy wheels use a silica gel desiccant permanently bonded without adhesives to the heat exchange surface; therefore, the desiccant will not be washed off in the cleaning process. Trane energy wheels larger than 30 inches in diameter are made with removable segments for easy cleaning. Proper cleaning of the energy wheel should restore latent effectiveness to near original performance.

A detailed cleaning procedure can be found in the appropriate installation, operation, and maintenance manual (CLCH-SVX03A-EN for T-Series energy wheels and CLCH-SVX04A-EN for MCC energy wheels).



MCC Dimensions and Weights

The two configurations detailed below are the more common arrangements for

MCC energy wheel units. To obtain dimensions and weights for more unique configura-

tions, contact Lexington marketing at 800-228-1666, extension 2615.

Figure 7. MCC dimensional data

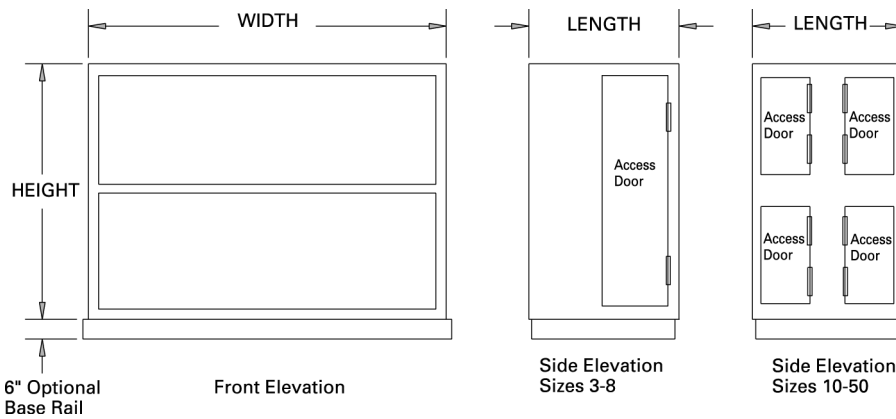

Table 6. MCC module dimensions and weights: 100% outside air¹ (no dampers)

Unit Size	Access Door	Module Length	Module Width	Module Height	Weight (lb.)
3	24 x 52	36	38	49 ³ / ₄	503
6	24 x 52	36	44	54 ³ / ₄	683
8	24 x 52	36	52	62 ¹ / ₄	707
10	11 ¹ / ₂ x 30	43 ³ / ₄	64	68 ¹ / ₄	916
12	11 ¹ / ₂ x 34	43 ³ / ₄	68	76 ¹ / ₄	1161
14	13 ¹ / ₂ x 36	47 ³ / ₄	72	80 ¹ / ₄	1215
17	13 ¹ / ₂ x 40	47 ³ / ₄	78	88 ¹ / ₄	1319
21	17 ¹ / ₂ x 44 ¹ / ₂	55 ³ / ₄	80	97 ¹ / ₄	1585
25	21 x 50 ³ / ₄	62 ³ / ₄	90	109 ³ / ₄	1732
30	21 ³ / ₈ x 50 ³ / ₄	62 ³ / ₄	95	109 ³ / ₄	2076
35	20 ¹ / ₂ x 57	62 ³ / ₄	100	124 ¹ / ₄	2141
40	20 ¹ / ₂ x 57	62 ³ / ₄	113	124 ¹ / ₄	2369
50	20 ¹ / ₂ x 69	62 ³ / ₄	120	148 ¹ / ₄	2680

1. Module dimensions and weights are subject to change without notice. Refer to the Trane submittals for current dimensions and weights.



Table 7. MCC module dimensions (inches) and weights: partial outside air¹ (one recirculating and two bypass dampers)

Unit Size	Access Door	Module Length	Module Width	Module Height	Weight (lb.)
3					
6	32 x 25½	49¾	44	58	657
8	32 x 29¼	49¾	48	62¼	685
10	14½ x 30	49¾	60	68¼	975
12	14½ x 34	49¾	64	76¼	1034
14	14½ x 36	49¾	68	80¼	1175
17	14½ x 40	49¾	74	86¼	1320
21	17½ x 44	55¾	76	97¼	1571
25	21 x 50¾	62¾	78	109¾	1737
30	21¾ x 50	62¾	91	109¾	2033
35	20½ x 57	62¾	96	124¼	2104
40	20½ x 57	62¾	109	124¼	2235
50	20½ x 69	62¾	120	148¼	2463

1. Module dimensions and weights are subject to change without notice. Refer to the Trane submittals for current dimensions and weights.

Table 8. MCC module dimensions (inches) and weights: 100% outside air with variable effectiveness¹ (one bypass damper)

Size	Access Door	Module Length	Module Width	Module Height	Weight (lb.)
3	24 x 45¾	36	38	50½	503
6	24 x 50¾	36	44	56½	683
8	24 x 58¼	36	52	64½	707
10	11½ x 32	43¾	64	73½	916
12	11½ x 32	43¾	68	79½	1161
14	13½ x 34	47¾	72	90¼	1215
17	13½ x 34	47¾	78	94	1319
21	17½ x 39	55¾	80	98	1585
25	21 x 39	62¾	90	109¾	1732
30	21¾ x 46	62¾	95	113½	2076
35	20½ x 48	62¾	100	124¼	2141
40	20½ x 48	62¾	113	131	2369
50	20½ x 55	62¾	120	148¼	2680

1. Module dimensions and weights are subject to change without notice. Refer to the Trane submittals for current dimensions and weights.

T-Series Dimensions and Weights

Figure 8. T-Series dimensional data, plan view: partial outside air

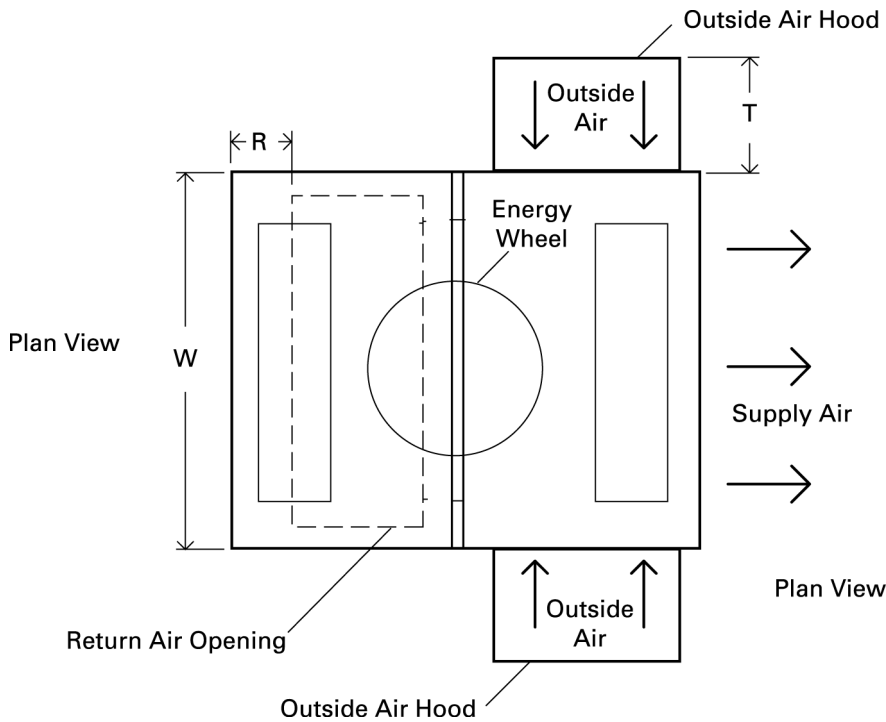
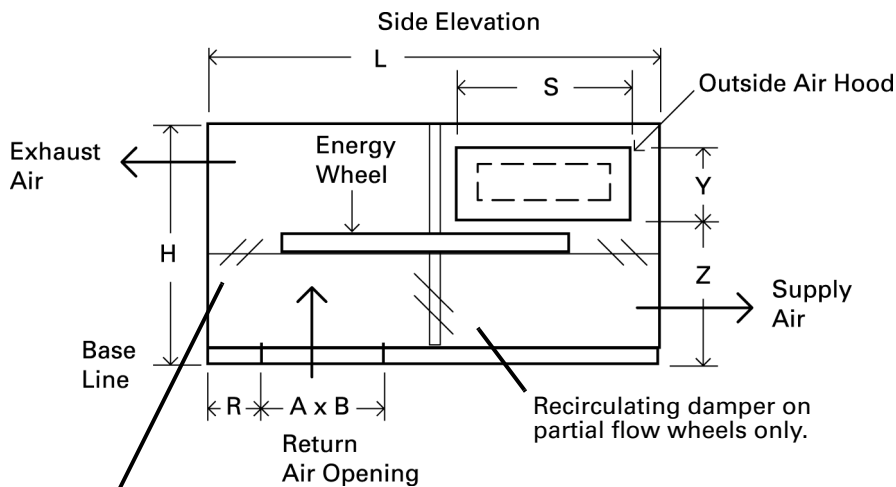

Figure 9. T-Series dimensional data, side elevation



Only one bypass damper is allowed on a 100% outside air section

**Table 9. T-Series energy wheel section dimensions (inches) and weights: 100% outside air¹
(maximum of one bypass damper)**

Unit Size	Section Dimensions			Outside Air Hood				Return Air			Weight (lb)
	W	H	L	S	Y	Z	T	R	A	B	
8	54	38.75	68.50	21.50	19.67	12.50	17.00	11.5	13.88	34.63	631
10	66	41.75	83.50	34.50	19.67	15.50	17.00	13	19.63	55.13	854
12	70	45.75	83.50	34.50	19.67	19.50	17.00	14.5	19.63	59.13	951
14	74	48.75	99.00	38.50	19.67	21.50	17.00	16	19.63	63.13	1308
17	80	52.75	99.00	38.50	19.67	25.50	17.00	16	25.38	69.13	1389
21	82	57.75	108.00	46.75	25.27	24.50	20.50	19	25.38	71.13	1605
25	84	63.50	115.50	50.75	25.27	30.75	20.50	19	31.13	73.13	1755
30	97	63.50	120.00	50.75	25.27	30.63	20.50	22	31.13	86.13	2213
35	102	72.75	127.00	54.00	30.97	34.25	24.00	22	36.88	90.13	2563
40	115	72.75	135.00	54.00	30.97	34.25	24.00	23	36.88	103.13	2864
50	126	85.00	148.50	64.50	36.73	40.50	27.63	26	36.88	114.13	3484

1. Section dimensions and weights subject to change without notice. Refer to Trane submittals for current dimensions and weights.

**Table 10. T-Series energy wheel section dimensions (inches) and weights: partial outside air¹
(one recirculating and two bypass dampers)**

Unit Size	Section Dimensions			Outside Air Hood				Return Air			Weight (lb)
	W	H	L	S	Y	Z	T	R	A	B	
8	54	38.75	79.00	21.50	19.67	12.50	17.00	11.5	13.88	34.63	686
10	66	41.75	83.50	34.50	19.67	15.50	17.00	13	19.63	55.13	916
12	70	45.75	83.50	34.50	19.67	19.50	17.00	14.5	19.63	56.13	985
14	74	48.75	99.00	38.50	19.67	21.50	17.00	16	19.63	63.13	1168
17	80	52.75	99.00	38.50	19.67	25.50	17.00	16	25.38	69.13	1312
21	82	57.75	108.00	46.75	25.27	24.50	20.50	19	25.38	71.13	1524
25	84	63.50	115.50	50.75	25.27	30.75	20.50	19	31.13	73.13	1690
30	97	63.50	120.00	50.75	25.27	30.63	20.50	22	31.13	86.13	1906
35	102	72.75	127.00	54.00	30.97	34.25	24.00	22	36.88	90.13	2497
40	115	72.75	135.00	54.00	30.97	34.25	24.00	23	36.88	103.13	2783
50	126	85.00	148.50	64.50	36.73	40.50	27.63	26	36.88	114.13	3527
66	141	97.00	152.00	71.00	42.53	46.75	31.18	30	43.50	130.25	4145
80	141	112.00	152.00	71.00	48.13	56.13	34.63	30	49.25	130.25	4313
100	156	124.50	152.00	71.00	70.42	46.38	48.33	30	55	145.25	4816

1. Section dimensions and weights subject to change without notice. Refer to Trane submittals for current dimensions and weights.



The Trane Company
An American Standard Company
www.trane.com

For more information, contact your local district office or e-mail us at comfort@trane.com

Literature Order Number	CLCH-PRC006-EN
File Number	PL-AH-CLCH-PRC006-EN-0801
Supersedes	CLCH-PRB002-EN and CLCH-PRB008-EN
Stocking Location	La Crosse

Since The Trane Company has a policy of continuous product and product data improvement, it reserves the right to change design and specifications without notice.